

FT743-SM (SURFACE MOUNT)



ACOUSTIC RESONANCE WIND SENSOR

UNIQUE ACU-RES® TECHNOLOGY

Acoustic Resonance (Acu-Res®) is fundamentally different to other ultrasonic sensors on the market, delivering exceptionally high levels of data availability even in environments where there is significant vibration or electrical noise. Measuring wind speeds up to 75m/s and with full 360° direction measurement, Acu-Res® delivers a stronger signal-to-noise ratio than other ultrasonic technologies. FT wind sensors are instant response (10Hz), impact resistant (50g), water-tight (IP67) and highly accurate.

EXTREME SURVIVABILITY

With an anodised aluminium construction that is corrosion-resistant, sealed to IP67 and incorporates a powerful heating system, FT wind sensors provide reliable wind data, even in the harshest of environments. All FT wind sensors undergo a rigorous set of tests including vibration and shock, water-proofing and sealing, temperature and EMC to ensure maximum reliability.

PROVEN PERFORMANCE

FT is the wind sensor of choice for wind turbine control and used for a wide range of industrial applications where wind data is critical. Wind speed, direction, temperature, pressure and compass data in an industrial-grade package that fits in your hand. The FT743-SM wind sensor is trusted for precision control data for manned and unmanned systems on land, sea and in the sky.

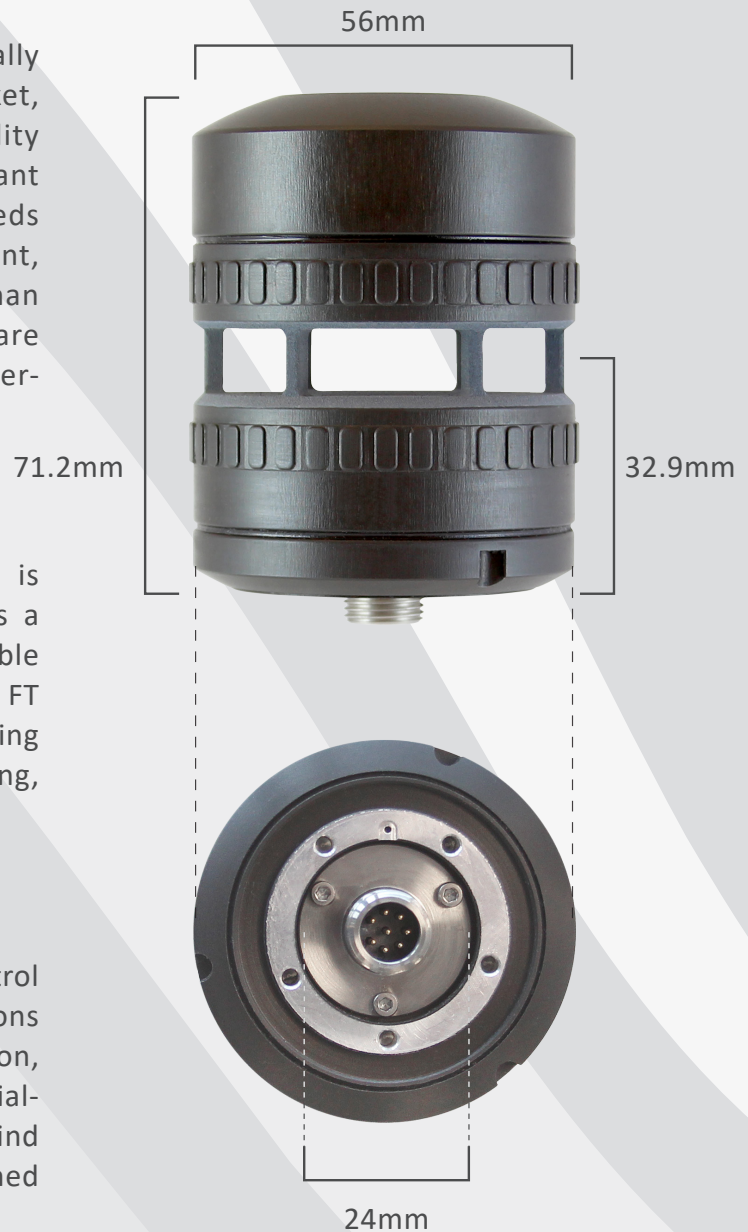

SPECIFICATIONS AT A GLANCE

WIND SPEED

0-75 m/s

WEIGHT

252 g

AVAILABILITY

> 99.9 %

FT743-SM (SURFACE MOUNT)



WIND SPEED ³

Range.....	0-75m/s.....	0-270km/h.....	0-145.8 knots
Resolution.....	0.1m/s.....	0.1km/h.....	0.1knots
Accuracy.....	±0.3m/s (0-16m/s)		
	±2% (16-40m/s)		
	±4% (40-75m/s)		

WIND DIRECTION

Range.....	0 to 360°
Resolution.....	1°
Accuracy.....	4° RMS
Compass accuracy.....	5° RMS

PRESSURE MEASUREMENT

Range.....	.260 - 1260hPa
Resolution.....	0.0001hPa
Accuracy.....	±0.5%

ACOUSTIC TEMPERATURE

Resolution.....	0.1°C
Accuracy.....	±2°C
Under the following conditions:	
Speed Range.....	5m/s - 60m/s
Operating Range.....	-20°C to +60°C
Temperature Difference.....	<10°C
between the air temperature and the actual temperature of the sensor.	

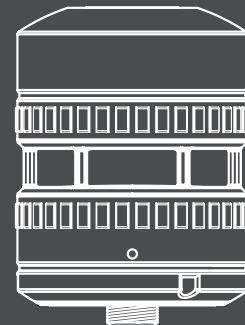

SENSOR PERFORMANCE

Measurement principle.....	Acoustic Resonance (automatically compensates for variations in temperature, pressure & humidity)
Units of measure.....	Metres per second, kilometres per hour or knots
Altitude.....	0-4000m operating range
Temperature range.....	-40° to +85°C (operating and storage)
Humidity.....	0-100%
Ingress protection.....	IP67 - when correctly installed with supplied O-ring
Heater settings.....	0° to 55°C (user configurable)

POWER REQUIREMENTS

Supply voltage.....	.6V to 30V DC (24V DC nominal). Supports battery operation with reduced heater capacity. ²
Supply current (heater off).....	.25mA typical (29mA with compass enabled)
Supply current (heater on).....	.2A ¹

PHYSICAL

I/O connector.....	.Universal M12 8-pole circular connector
Sensor weight.....	.252g

DIGITAL SENSOR

Interface.....	.RS422 (full-duplex). RS485 (half-duplex)
Format.....	.ASCII data, polled or continuous output modes, Polar and NMEA 0183
Data update rate.....	.10Hz
Error handling.....	.When the sensor detects an invalid reading an error flag is included in the wind velocity output message
Overspeed Warning.....	.If the sensor detects a wind speed greater than 75 m/s a warning flag is set in the wind velocity output message. This scheme is disabled by default.

¹ Heater control is achieved through a closed loop system, therefore the power consumption of the heater is a function of the applied cooling load on the sensor and the user temperature set point. Maximum heating power is 60 W at 30 V.

² EN 61000-4-29 only applicable when the sensor power supply is between 20V to 30V DC.

³ km/h & knots only available when operating the sensor in NMEA 0183 mode.